

Hotel/Motel Tax Funding Request

Organization Name: Davis County Trails Council
Address: 23334 215th Street, Bloomfield, IA 52537
Contact Person: Rich Fetcho Phone: 641-208-9611
Purpose of Organization: Development of Community Trail System
Amount Requested this Year: \$ ALL Available Funds

Please describe what these funds will be used for if awarded: Development of trail Pathway (YA). See Insert.

Attach a copy of your organization's current budget and proposed budget for next year, including revenue and expense estimates.

Does your organization utilize the services of a professional fundraiser? Yes No

Name: _____
Address: _____

Please list the source and amount of funds available for the project. Do not include Hotel/Motel funds.

Davis County Trails Council currently has \$91,000.00 Available.

Person Completing this Form: Rich Fetcho
Address: 23334 215th Street
Signature: Richard James Fetcho Date: 1/17/2022

Include any additional information or supporting documentation for your request that you feel would be helpful.

Submit Completed Report to: City of Bloomfield, 111 West Franklin Street, Bloomfield, IA 52537

<i>This Box For Office Use Only</i>	
Date Request Received in Office	_____
Date Considered by Council	_____
Amount Awarded	_____
Applicant Notified	_____

JAN 19 22
2:35P

IOWA

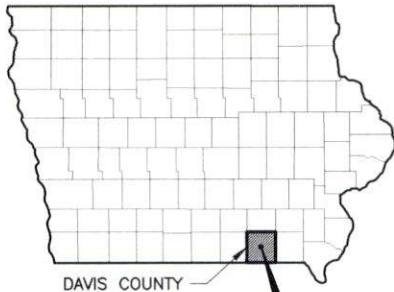

DAVIS COUNTY

BLOOMFIELD, IOWA

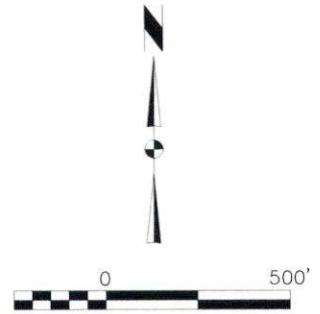

PROJECT LOCATION



DRAWING PATH: NAME: S:\SIP\Bloomfield\Trails\Phase 4_5 Fair Baseball Trail\ORANT SKETCHES.dwg - COVER (1)
PLOTTED: 01/18/22 - 3:25pm - stephemp

1200
1/14/2022
SHEET 1 OF 3

GENERAL LAYOUT
PHASE 4
BLOOMFIELD, IOWA



FRENCH-RENEKER-ASSOCIATES
ENGINEERS & SURVEYORS

DRAWING PATH: S:\SIP\Bloomfield\Trails\Phase 4_5 Fair Baseball Trail\GRANT SKETCHES.dwg - PHASE 4A and B
PLOTTED: 01/18/22 - 3:25pm - stephen

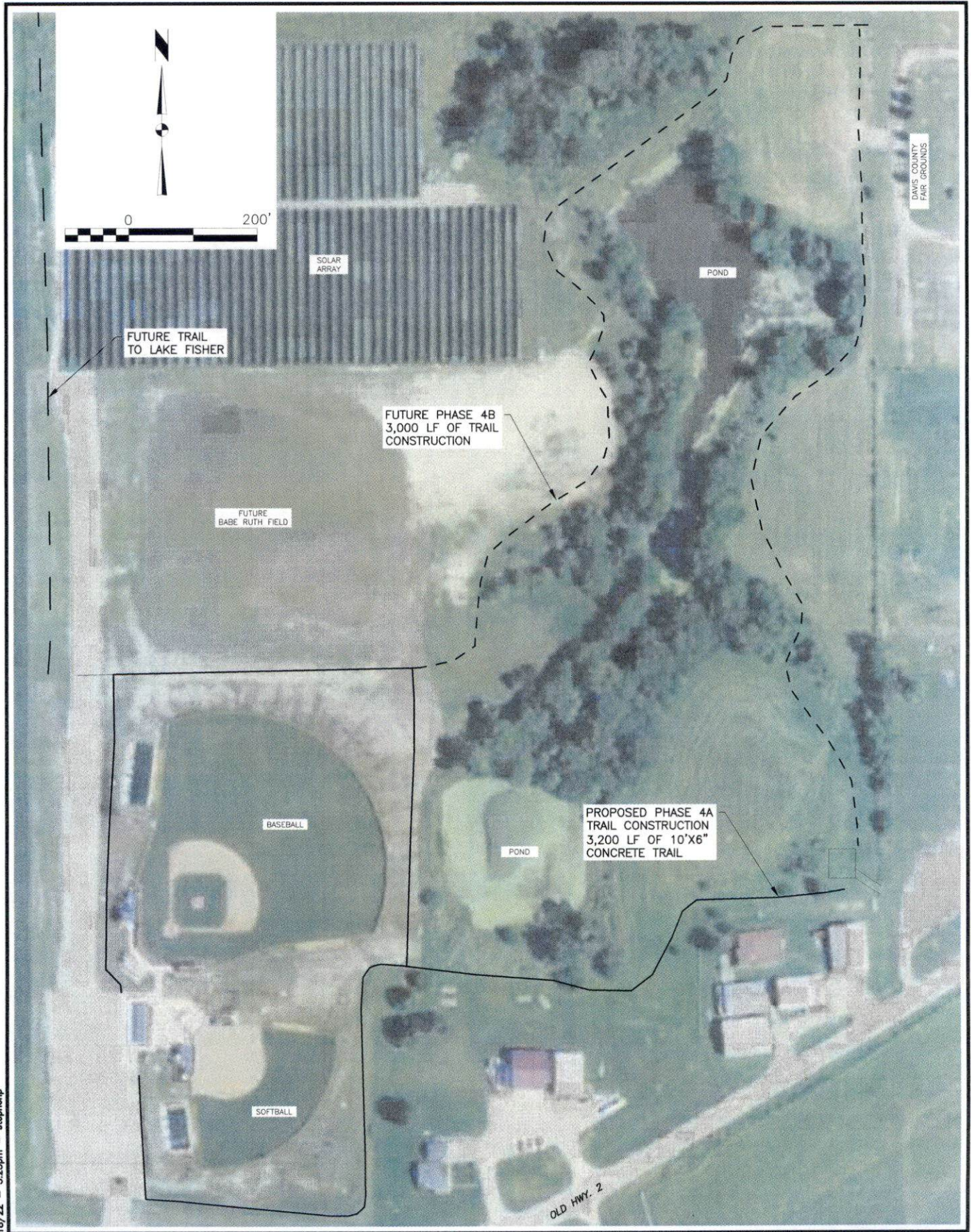

1200
1/14/2022
SHEET 2 OF 3

PLAN VIEW
PHASE 4A TRAIL CONSTRUCTION
BLOOMFIELD, IOWA



FRENCH-RENEKER-ASSOCIATES
ENGINEERS & SURVEYORS

PHASE 4A TYPICAL SECTION AND DETAILS - TRAIL AND SIDEWALK

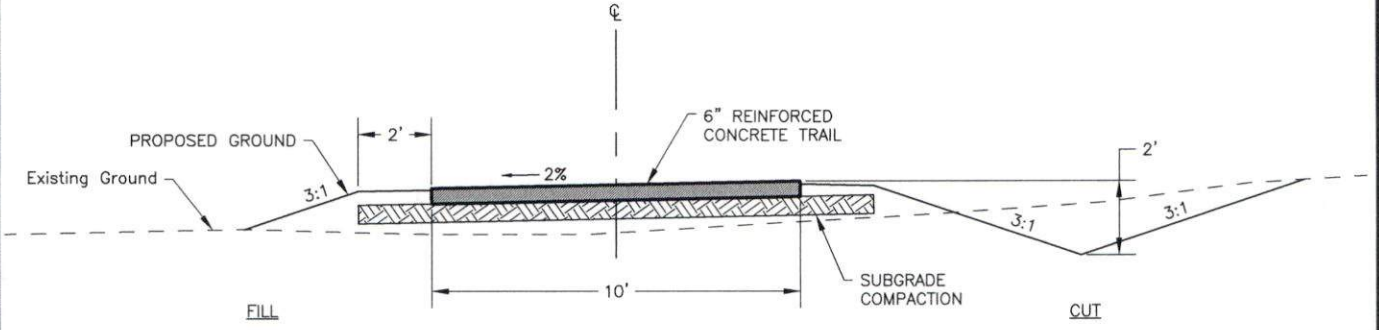

**PHASE 4A
TYPICAL SECTION**

1200
1/14/2022
SHEET 3 OF 3

TYPICAL SECTION AND DETAILS
PROPOSED TRAIL CONSTRUCTION
BLOOMFIELD, IOWA

 **FRENCH-RENEKER-ASSOCIATES**
ENGINEERS & SURVEYORS

**OPINION OF PROBABLE COST
PROPOSED RECREATION TRAIL
DAVIS COUNTY TRAIL - PHASE 4
DAVIS COUNTY BALL FIELDS
DAVIS COUNTY, IOWA-JANUARY 2022**

4A 3,200 LF of 10'x6" PCC Trail

1200

Item No.	Description	Quantity	Unit Price	Extension
1	Mobilization	1 L.S.	\$ 21,930.00	\$ 21,930.00
2	Traffic Control	1 L.S.	\$ 1,500.00	\$ 1,500.00
3	Clearing and Grubbing	1 L.S.	\$ 3,000.00	\$ 3,000.00
4	Topsoil; Strip, Salvage, and Spread	1,400 C.Y.	\$ 11.00	\$ 15,400.00
5	Class 10 Excavation	2,500 C.Y.	\$ 15.00	\$ 37,500.00
6	Special Compaction of Subgrade	36.0 Sta.	\$ 220.00	\$ 7,920.00
7	Granular Foundation Material	150 Ton	\$ 35.00	\$ 5,250.00
8	Granular Surfacing-Class A Road Stone	100 Ton	\$ 27.00	\$ 2,700.00
9	Earth Shoulder Finishing	72.0 Sta.	\$ 200.00	\$ 14,400.00
10	Reinforced Concrete Trail, 6"	4,400 S.Y.	\$ 47.00	\$ 206,800.00
11	7" Reinforced PCC Pavement	750 S.Y.	\$ 60.00	\$ 45,000.00
12	Curb and Gutter Unit, 30"	300 L.F.	\$ 50.00	\$ 15,000.00
13	Detectable Warning Panels	100 S.F.	\$ 40.00	\$ 4,000.00
14	Bollard, Removable Steel	6 Each	\$ 3,000.00	\$ 18,000.00
15	Fence, Chain Link, Vinyl Coated, 48" Height	60 L.F.	\$ 30.00	\$ 1,800.00
16	Signage	1 L.S.	\$ 5,000.00	\$ 5,000.00
17	Culverts	120 L.F.	\$ 80.00	\$ 9,600.00
18	Aprons	8 Each	\$ 2,200.00	\$ 17,600.00
19	Repair of Existing Drains	8 Each	\$ 200.00	\$ 1,600.00
20	Tiling, 4" or 6"	240 L.F.	\$ 5.00	\$ 1,200.00
21	Class D Revetment	80 Ton	\$ 45.00	\$ 3,600.00
22	Temporary Seeding	2.50 Acre	\$ 2,500.00	\$ 6,250.00
23	Permanent Seeding and Fertilizing	2.50 Acre	\$ 4,000.00	\$ 10,000.00
24	Mulching	5.0 Acre	\$ 1,000.00	\$ 5,000.00
25	Wood Excelsior Mat	50 Sq.	\$ 25.00	\$ 1,250.00
26	Silt Fence; Furnish, Install, and Maintain	1,300 L.F.	\$ 3.00	\$ 3,900.00
27	Silt Fence Removal	1,300 L.F.	\$ 1.00	\$ 1,300.00
28	SWPPP Maintenance	1 L.S.	\$ 1,500.00	\$ 1,500.00
Estimated Construction Costs				\$ 468,000.00
Contingencies				\$ 70,000.00
Engineering				\$ 94,000.00
Grant Applications and Administration				\$ 20,000.00
Total Project Costs				\$ 652,000.00